

PLAY-ALONG CD AND
START-UP VIDEO

Book 1 Violin

ESSENTIAL ELEMENTS 2000

for Strings



A COMPREHENSIVE STRING METHOD

BY

MICHAEL ALLEN

ROBERT GILLESPIE

PAMELA TELLEJOHN HAYES

ARRANGEMENTS BY

JOHN HIGGINS



HAL•LEONARD®
CORPORATION

THE VIOLIN

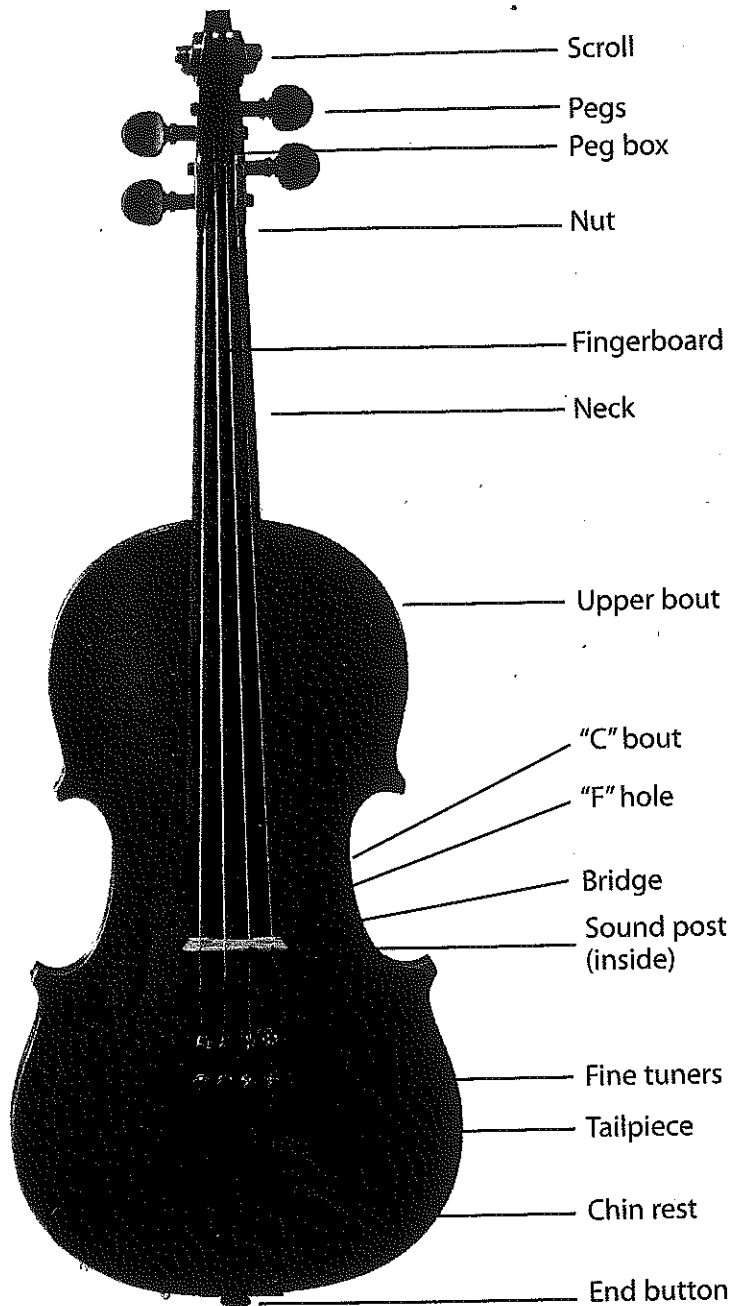

Take Special Care

String instruments are delicate. Follow your teacher's guidelines in caring for your instrument, and it will last forever.

- Follow your teacher's instructions when removing the instrument from the case.
- Protect your instrument from heat, cold, and quick changes in temperature.
- Always wipe off the instrument with a soft dry cloth. Be sure to remove all fingerprints and rosin.
- Place a cloth over the top of the violin before closing the case.

Accessories

- Rosin
- Shoulder rest
- Soft cloth
- Extra set of strings

THE BOW



- Never touch the bow hair.
- Keep the bow in your case until directed by your teacher.

HOLDING YOUR INSTRUMENT

The best way to learn to play your instrument is to practice one skill at a time. Repeat each step until you are comfortable demonstrating it for your teacher and classmates.

Many violin players begin by playing their instrument in guitar position. As you learn the basics, your teacher will help you change to shoulder position.

Guitar Position

- Step 1** Place the instrument case flat on the floor with the handle facing you. Open the case and lift the instrument up by the neck. Identify all parts of the violin.
- Step 2** Cradle the violin under your right arm. Raise the scroll to shoulder height. Be sure the back of the violin is flat against your stomach.
- Step 3** Identify the letter names of each string: G (lowest pitch), D, A, E.
- Step 4** Raise your right thumb over the strings while continuing to hold the instrument. Pluck the strings as directed by your teacher. Plucking the strings is called *pizzicato*, and is abbreviated *pizz.*

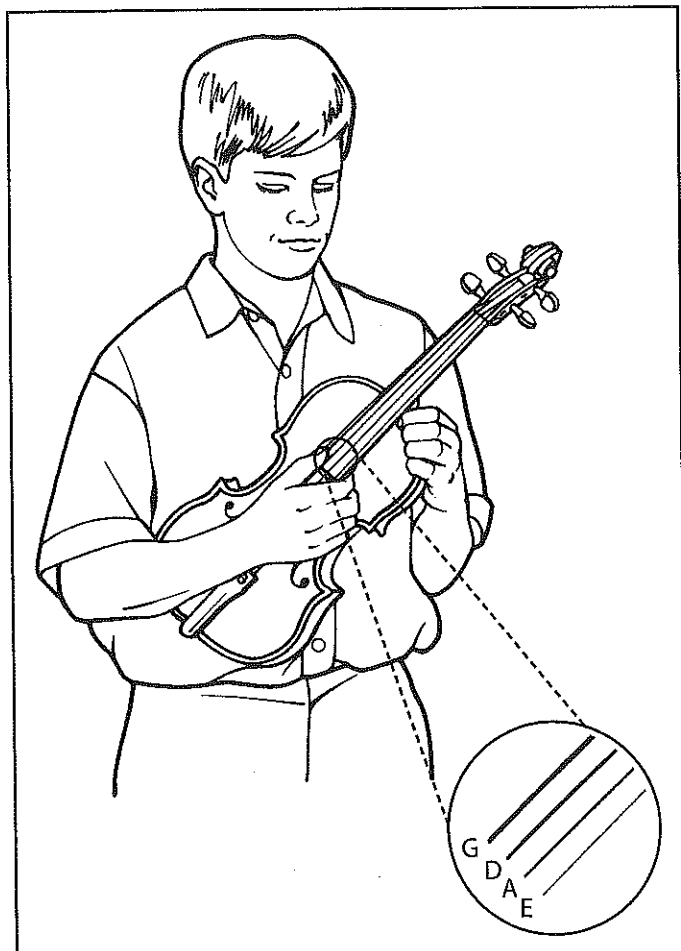

Guitar Position

Shoulder Position

- Step 1** (*Standing*) – Stand with feet about a shoulder's width apart. (*Sitting*) – Sit on the front part of the chair.
- Step 2** Turn your left foot to the 10 o'clock position. Slide your right foot back. Adjust your position to place more weight on your left foot.
- Step 3** Hold your instrument at eye level parallel to the floor. Curve your left hand around the upper bout. Find the end button with your right hand.
- Step 4** Bring the instrument down to your shoulder. The end button should be near the middle of your neck. Turn your head slightly to the left, and place your jaw on the chin rest. Be sure the scroll does not point toward the floor.

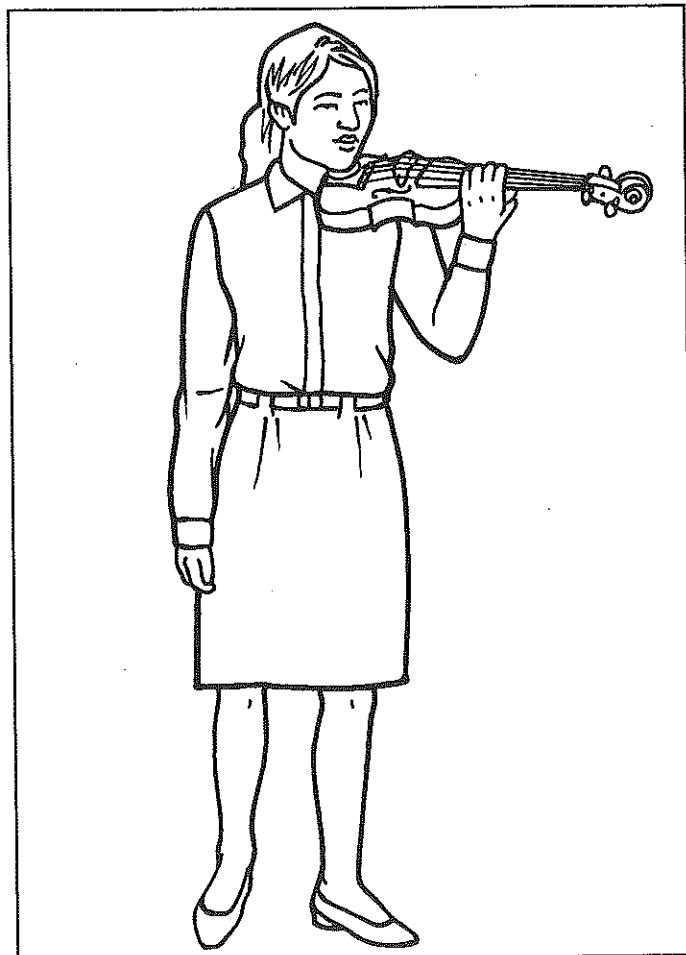

Shoulder Position

Beat = The Pulse of Music

The **beat** in music should be very steady, just like your pulse.

Quarter Note ♩ = 1 Beat of Sound

Notes tell us how high or low to play, and how long to play.

Quarter Rest { = 1 Beat of Silence

Rests tell us to count silent beats.

Music Staff The **music staff** has 5 lines and 4 spaces.

Bar Lines **Bar lines** divide the music staff into **measures**.

Measures The **measures** on this page have four beats each.

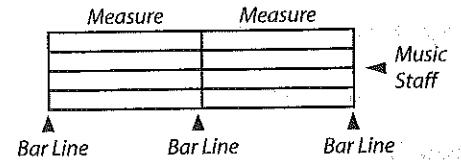

1. TUNING TRACK Wait quietly for your teacher to tune your instrument.

2. LET'S PLAY "OPEN D"

Pizzicato (pizz.) ↪ Pluck the strings

0 ↪ Open string

D

3. LET'S PLAY "OPEN A"

pizz.
0

A

Keep a steady beat.

4. TWO'S A TEAM

pizz.

5. AT PIERROT'S DOOR The melody is on your CD.

pizz.

Treble Clef

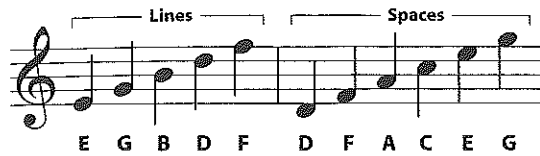

Clefs indicate a set of note names.

Time Signature (Meter)

4 4 beats per measure
4 ♩ or ♪ gets one beat

The **time signature** tells us how many beats are in each measure and what kind of note gets one beat.

Double Bar



A **double bar** indicates the end of a piece of music.

6. JUMPING JACKS Identify the clef and time signature before playing.

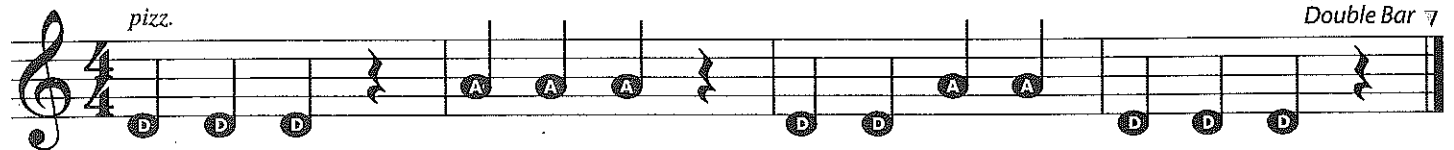

7. MIX 'EM UP

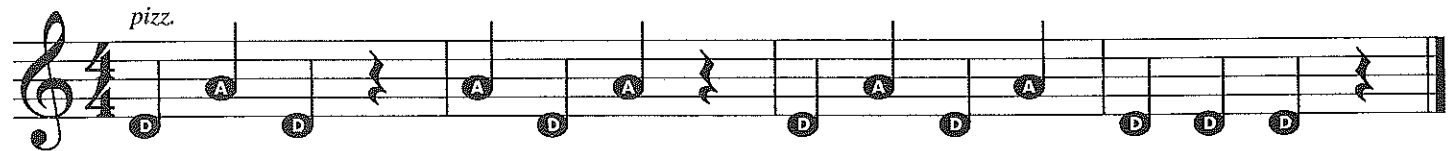

Repeat Sign

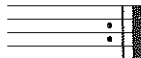

Go back to the beginning and play the music again.

Counting

Count	1	&	2	&	3	&	4	&
Tap	↓	↑	↓	↑	↓	↑	↓	↑

One beat = Tap toe down on the number and up on "&." Always count when playing or resting.

8. COUNT CAREFULLY Keep a steady beat when playing or resting.

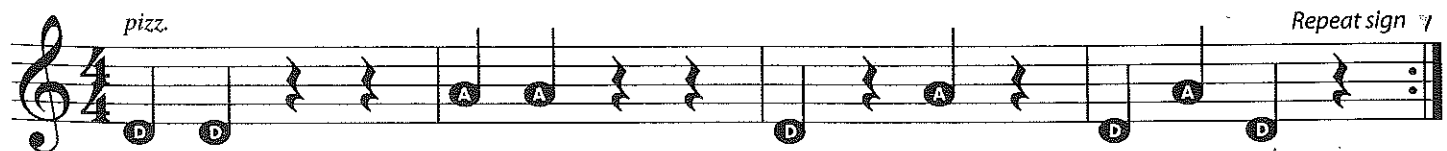

Count: 1 & 2 & 3 & 4 & 1 & 2 & 3 & 4 & 1 & 2 & 3 & 4 & 1 & 2 & 3 & 4 &

9. ESSENTIAL ELEMENTS QUIZ Write in the counting before you play.

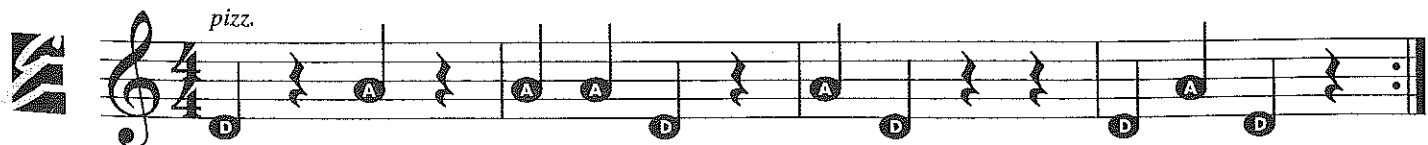

SHAPING THE LEFT HAND

D STRING NOTES

Step 1 Shape your left hand as shown.
Be certain your palm faces you.

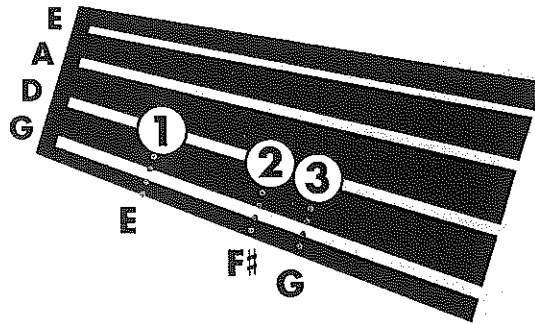
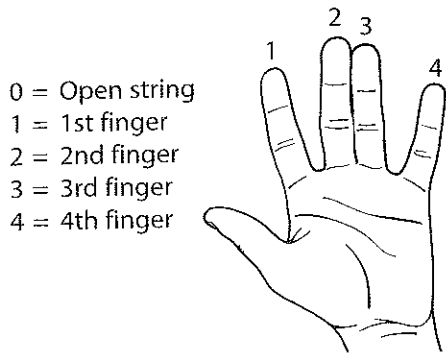

Step 2 Bring your hand to the fingerboard. Place your fingers on the D string, keeping your hand shaped as shown below.
Be sure your first finger forms a square with the fingerboard, and your wrist is relaxed and straight.

G is played with 3 fingers on the D string.

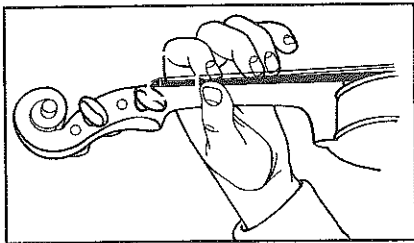

F# is played with 2 fingers on the D string.

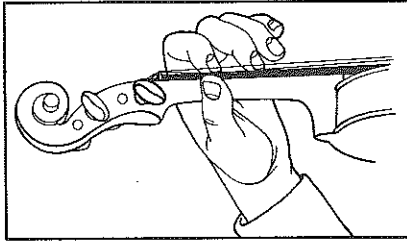

E is played with 1 finger on the D string.

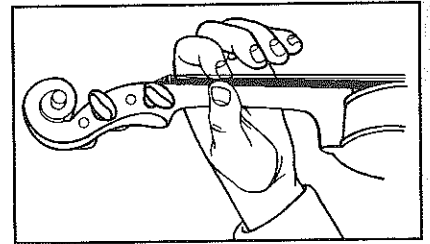

Listening Skills Play what your teacher plays. Listen carefully.

10. LET'S READ "G" Start memorizing the note names.

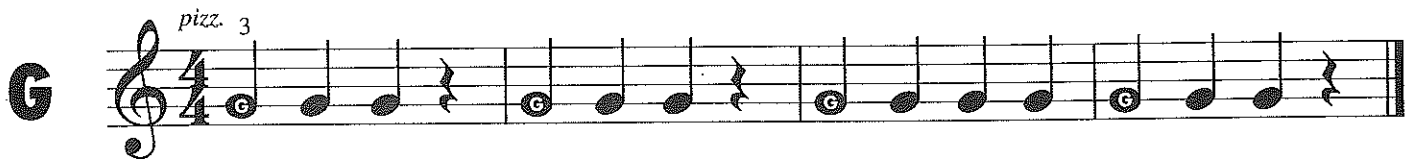

THEORY

Sharp #

A **sharp** raises the sound of notes and remains in effect for the entire measure. Notes without sharps are called **natural** notes.

11. LET'S READ "F#" (F-sharp)

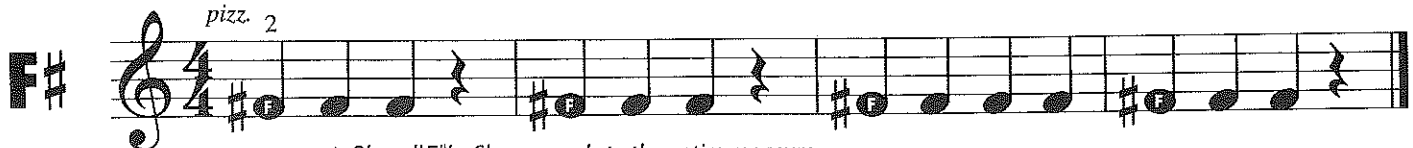

△ Play all F#'s. Sharps apply to the entire measure.

12. LIFT OFF

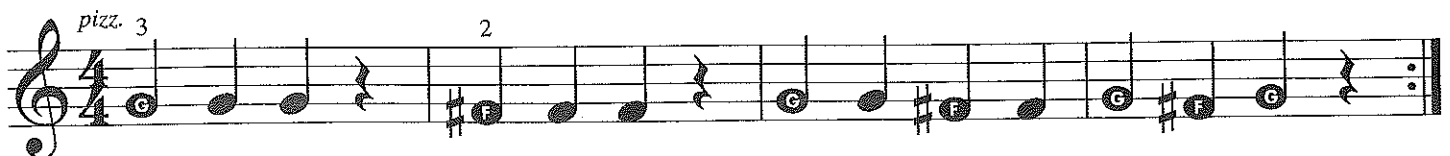

✓ Is your left hand shaped as shown in the diagrams above?

SHAPING THE RIGHT HAND

BOW BUILDER ONE

Pencil Hold

Step 1 Hold a pencil in your left hand at eye level.

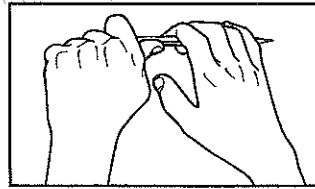

Step 2 Hang your right fingers over the top of the pencil, as shown.

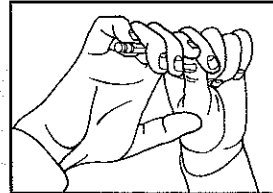

Step 3 Place your right 4th finger on top of the pencil.

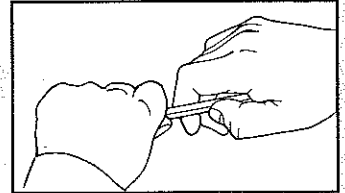

Step 4 Touch the tip of your right thumb to the pencil just opposite your 2nd finger. The curve of your thumb will form an oval with the finger.

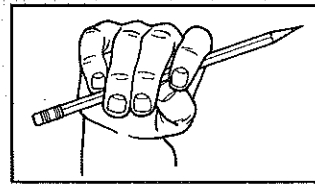

Step 5 Lean your right hand so the first finger rests on top of the pencil between the 1st and 2nd joints. Keep your fingers relaxed. Remove your left hand from the pencil. Practice shaping your hand on the pencil until it feels natural to you.

★ Practice BOW BUILDER ONE daily.

13. ON THE TRAIL *Say or sing the note names before you play.*

pizz.

14. LET'S READ "E"

pizz. 1

E

15. WALKING SONG

pizz. 3

2 1

Count: 1 & 2 & 3 & 4 & 1 & 2 & 3 & 4 & 1 & 2 & 3 & 4 & 1 & 2 & 3 & 4 &

16. ESSENTIAL ELEMENTS QUIZ *Draw the missing symbols where they belong before you play:*

pizz.

BOW BUILDER TWO

Pencil Hold Exercises

I'm Outta Here

Wave good-bye while keeping your wrist relaxed.

Thumb Flexers

Flex your thumb in and out.

Finger Taps

Tap your first finger. Then tap your fourth finger.

Knuckle Turnovers

Turn your hand over and be sure your thumb knuckle is bent, as shown.

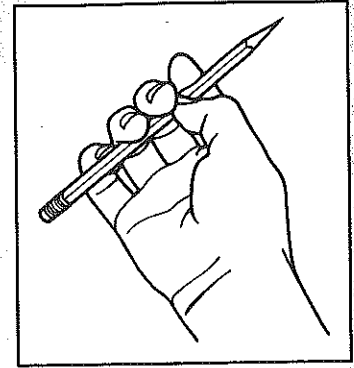

Knuckle Turnovers

BOW BUILDER THREE

Bowing Motions

Swingin' Out

Put one finger inside your right elbow and swing your arm, as shown.

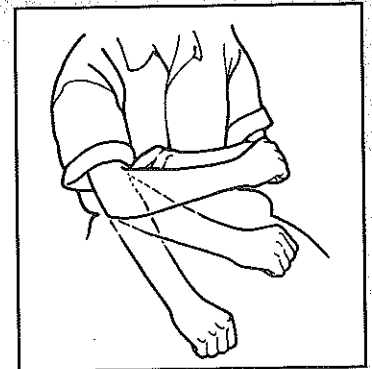

Swingin' Out

17. HOP SCOTCH

pizz.

Count: 1 & 2 & 3 & 4 & 1 & 2 & 3 & 4 & 1 & 2 & 3 & 4 & 1 & 2 & 3 & 4 &

HISTORY

Folk songs have been an important part of cultures for centuries and have been passed on from generation to generation. Folk song melodies help define the sound of a culture or region. This folk song comes from the Slavic region of eastern Europe.

18. MORNING DANCE

pizz. 3 2 0 1

Slavic Folk Song

19. ROLLING ALONG

pizz.

Go to next line. 7

WORKOUTS

Place your instrument in shoulder position as shown on page 3. Then practice the following exercises with your left hand.

Finger Taps

Tap fingertips on any string. Practice in different combinations of fingers.

Pull Aways

Pull your left hand away from the side of the neck, while keeping the thumb and fingers on the instrument.

Strummin' Along

Strum the strings with your 4th finger while swinging your elbow under the violin, as shown.

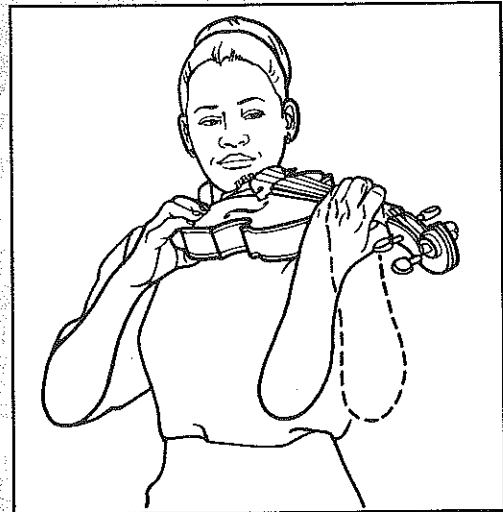

Strummin' Along

20. GOOD KING WENCESLAS

Welsh Folk Song

pizz. 3 0

Δ Keep fingers down when you see this bracket.

21. SEMINOLE CHANT

pizz.

Count: 1 & 2 & 3 & 4 & 1 & 2 & 3 & 4 & 1 & 2 & 3 & 4 & 1 & 2 & 3 & 4 &

22. ESSENTIAL ELEMENTS QUIZ - LIGHTLY ROW

pizz. 0 2 3 1

Δ Prepare F# before playing.

27. OLYMPIC HIGH JUMP

28. LET'S READ "B"

29. HALF WAY DOWN

30. RIGHT BACK UP

Scale A scale is a sequence of notes in ascending or descending order. Like a musical "ladder," each note is the next consecutive step of the scale. This is your D Scale. The first and last notes are both D.

THEORY

31. DOWN THE D SCALE Remember to memorize the note names.

32. ESSENTIAL ELEMENTS QUIZ - UP THE D SCALE

On The Bow (Early Bow Hold)

Step 1 Identify all parts of the bow (see page 2). Hold the bow in your left hand near the tip with the frog pointing to the right.

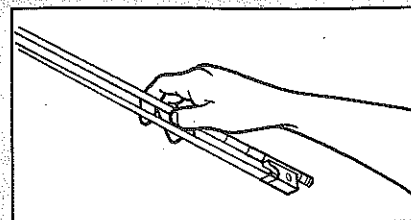

Balancing The Bow

Step 2 Put your right thumb and 2nd finger on the bow stick near the middle of the bow.

Step 3 Shape your right hand on the bow stick, as shown.

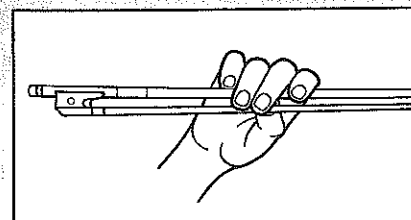

Early Bow Hold

Step 4 Turn your right hand over, and be sure your thumb and fingers are curved.

Step 5 Hold the bow and repeat the exercises on page 8.



Alert Do not place your bow on the instrument until instructed to do so by your teacher.

33. SONG FOR CHRISTINE

pizz.

34. NATALIE'S ROSE *Remember to count.*

pizz.

35. ESSENTIAL CREATIVITY *How many words can you create by drawing notes on the staff below?*

Example E G G

BOW BUILDER FOUR

On The Bow (Early Bow Hold)

Step 1 Identify all parts of the bow (see page 2). Hold the bow in your left hand near the tip with the frog pointing to the right.

Step 2 Put your right thumb and 2nd finger on the bow stick near the middle of the bow.

Step 3 Shape your right hand on the bow stick, as shown.

Step 4 Turn your right hand over, and be sure your thumb and fingers are curved.

Step 5 Hold the bow and repeat the exercises on page 8.

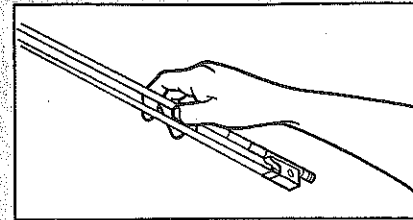

Balancing The Bow

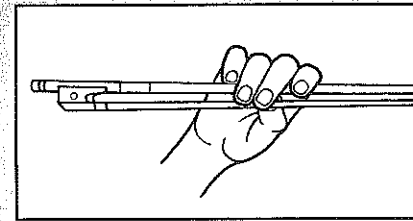

Early Bow Hold



Alert Do not place your bow on the instrument until instructed to do so by your teacher.

33. SONG FOR CHRISTINE

pizz.

34. NATALIE'S ROSE *Remember to count.*

pizz.

35. ESSENTIAL CREATIVITY *How many words can you create by drawing notes on the staff below?*

Example E G G

Review these notes. Write the letter names in the spaces below.

A musical staff in treble clef with a key signature of one sharp (F#). The notes are: G4, A4, B4, C5, B4, A4, G4. Below each note is a blank line for writing the letter name.

40. CAROLINA BREEZE

Musical staff for 'CAROLINA BREEZE' in 4/4 time, marked *pizz.*. The notes are: G4, A4, B4, C5, B4, A4, G4, F#4, G4, A4, B4, C5, B4, A4, G4, F#4, G4, A4, B4, C5, B4, A4, G4. Fingerings are indicated above the notes: 3, 2, 1, 0, 3, 2, 1, 2, 3. A count is provided below: **Count: 1 & 2 & 3 & 4 & 1 & 2 & 3 & 4 & 1 & 2 & 3 & 4 & 1 & 2 & 3 & 4 &**

41. JINGLE BELLS

J. S. Pierpont

Musical staff for 'JINGLE BELLS' in 4/4 time, marked *pizz.*. The notes are: G4, A4, B4, C5, B4, A4, G4, F#4, G4, A4, B4, C5, B4, A4, G4, F#4, G4, A4, B4, C5, B4, A4, G4, F#4, G4, A4, B4, C5, B4, A4, G4, F#4, G4, A4, B4, C5, B4, A4, G4. Fingerings are indicated above the notes: 2, 0, 0, 1, 3, 2, 1, 0, 2, 0, 3, 1, 0.

42. OLD MACDONALD HAD A FARM

American Folk Song

Musical staff for 'OLD MACDONALD HAD A FARM' in 4/4 time, marked *pizz.*. The notes are: G4, A4, B4, C5, B4, A4, G4, F#4, G4, A4, B4, C5, B4, A4, G4, F#4, G4, A4, B4, C5, B4, A4, G4, F#4, G4, A4, B4, C5, B4, A4, G4, F#4, G4, A4, B4, C5, B4, A4, G4. Fingerings are indicated above the notes: 3, 0, 1, 1, 0, 3, 0, 3, 0, 3, 0, 1, 0, 3.

BOW BUILDER SIX

Let's Bow!

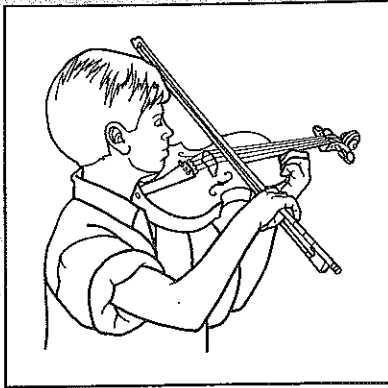

Early Bow Hold

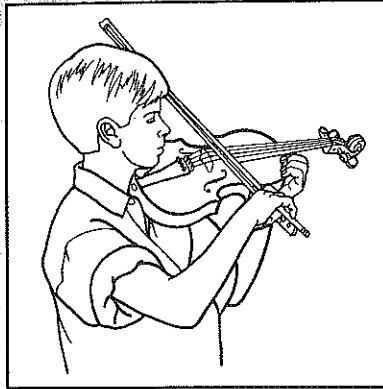

Regular Bow Hold

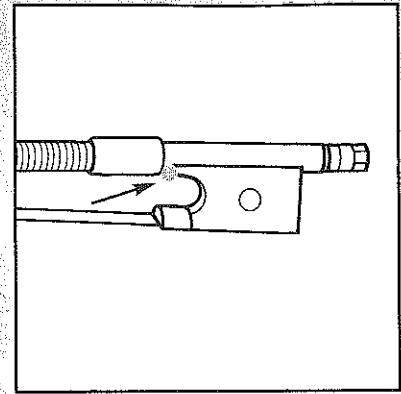

Thumb Placement

Step 1 Hold the instrument with your left hand on the upper bout as illustrated.

Step 2 Hold the bow at the balance point (Early Bow Hold). Your right elbow should be slightly lower than your hand.

Your teacher will suggest when to begin moving your bow hand toward the frog, as shown in the Regular Bow Hold illustration. The tip of your thumb will move to the place on the stick where it touches the frog.

Listening Skills

Play what your teacher plays. Listen carefully. Your tone should be smooth and even.

47. BOW ON THE D STRING

arco ↪ Play with the bow on the string.

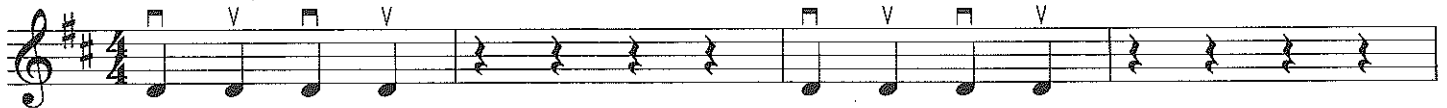

48. BOW ON THE A STRING

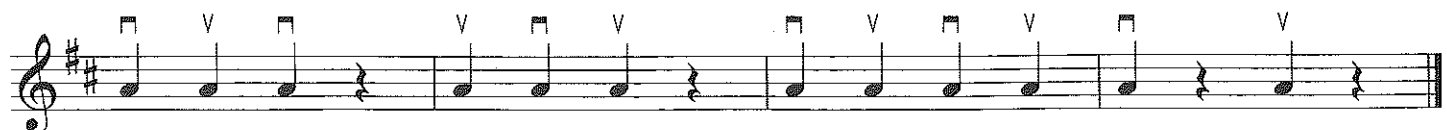
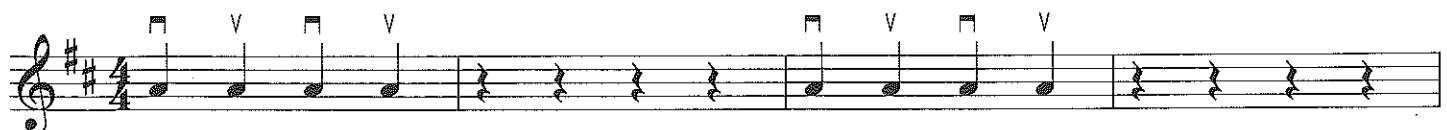

WORKOUTS

String Levels

Your arm moves when bowing on different strings. Memorize these guidelines:

- Raise your arm to play **lower**-pitched strings.
- Lower your arm to play **higher**-pitched strings.

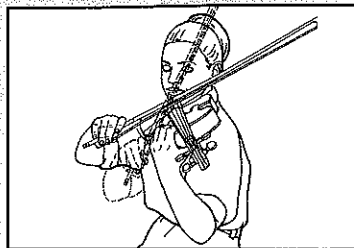

Raise arm = lower string
 Lower arm = higher string

49. RAISE AND LOWER

Musical notation for exercise 49 in G major, 4/4 time. The first four measures show a sequence of notes on the G string (G4, A4, B4, C5) with a 'V' above each note. The next four measures are rests, with the text 'Raise your arm.' written above. The final four measures show a sequence of notes on the E string (E4, D4, C4, B3) with a 'V' above each note. The text 'Lower your arm.' is written above the final two measures.

50. TEETER TOTTER

Musical notation for exercise 50 in G major, 4/4 time. It consists of four measures, each containing a pair of notes: G4 and E4, A4 and D4, B4 and C4, and C4 and B3. A 'V' is placed above each note.

51. MIRROR IMAGE

Musical notation for exercise 51 in G major, 4/4 time. It consists of four measures, each containing a pair of notes: G4 and E4, A4 and D4, B4 and C4, and C4 and B3. A 'V' is placed above each note.

Bow Lift ↷ Lift the bow and return to its starting point.

52. A STRAND OF D 'N' A

Musical notation for exercise 52 in G major, 4/4 time. It consists of four measures, each containing a pair of notes: G4 and E4, A4 and D4, B4 and C4, and C4 and B3. A 'V' is placed above each note. The final measure includes a 'Bow Lift' symbol (a curved line with a vertical tick) above the notes.

53. ESSENTIAL ELEMENTS QUIZ – OLYMPIC CHALLENGE

Musical notation for exercise 53 in G major, 4/4 time. It consists of four measures, each containing a pair of notes: G4 and E4, A4 and D4, B4 and C4, and C4 and B3. A 'V' is placed above each note.

BOW BUILDER SEVEN

Combining Both Hands

Using notes from the D major scale, echo what your teacher plays.

Example A:

 Musical notation for Example A in G major, 4/4 time. The first measure shows a sequence of notes: G4, A4, B4, C5. The second measure shows a sequence of notes: (D5, C5, B4, A4). This is followed by three empty measures for student practice. Labels 'Teacher' and 'Student' are placed below the first two measures.

Example B:

 Musical notation for Example B in G major, 4/4 time. The first measure shows a sequence of notes: G4, A4, B4, C5. The second measure shows a sequence of notes: (D5, C5, B4, A4). This is followed by three empty measures for student practice. Labels 'Teacher' and 'Student' are placed below the first two measures.

PUTTING IT ALL TOGETHER

Congratulations! You are now ready to practice like an advanced player by combining left and right hand skills while reading music. When learning a new line of music, follow these steps for success:

Step 1 Tap your toe and say or sing the letter names.

Step 2 Play *pizz.* and say or sing the letter names.

Step 3 Shadow bow and say or sing the letter names.

Step 4 Bow and play as written.

54. BOWING "G"



55. BACK AND FORTH

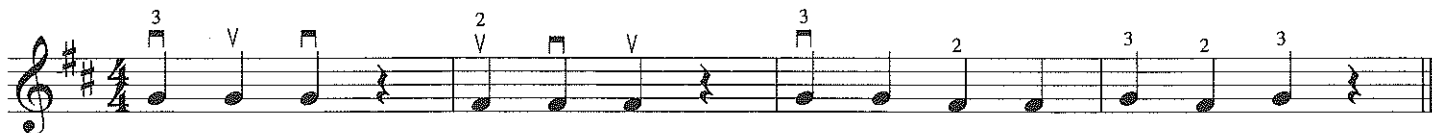

56. DOWN AND UP

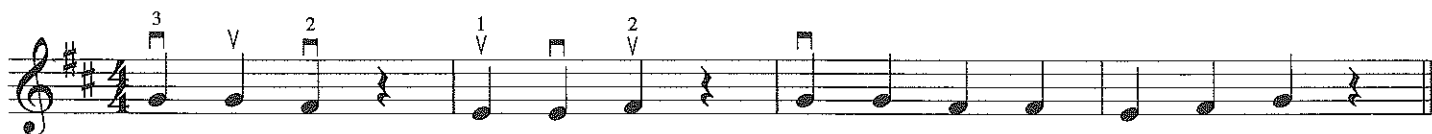

57. TRIBAL LAMENT

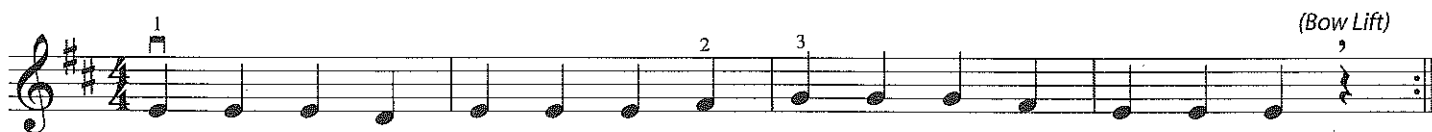

58. BOWING "D"



59. LITTLE STEPS

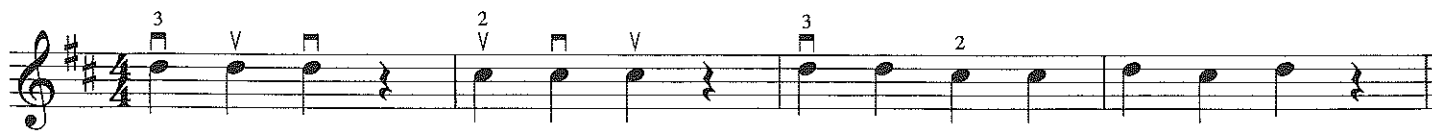

60. ELEVATOR DOWN

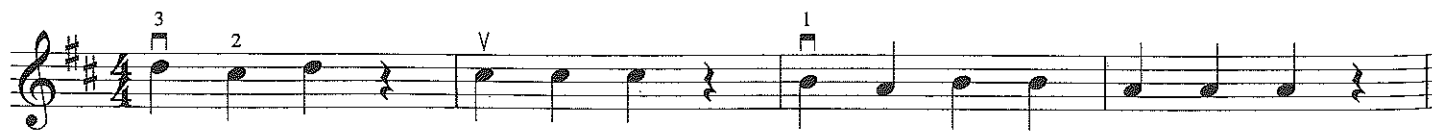

1 & 2 & 3 & 4 & 1 & 2 & 3 & 4 & 1 & 2 & 3 & 4 & 1 & 2 & 3 & 4 &

61. ELEVATOR UP

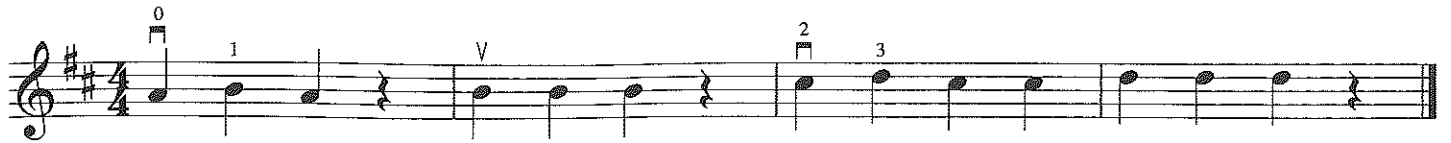

62. DOWN THE D MAJOR SCALE

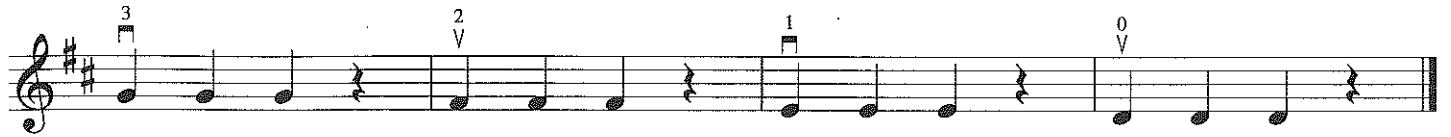

63. SCALE SIMULATOR *Remember to count.*

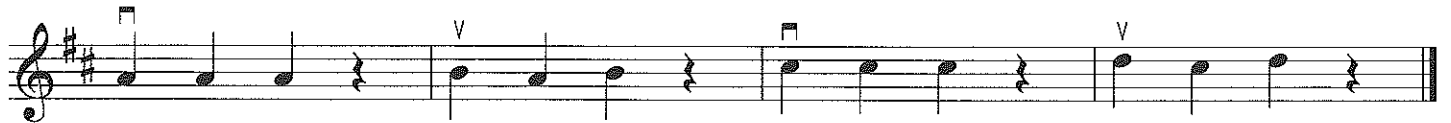

64. ESSENTIAL ELEMENTS QUIZ – THE D MAJOR SCALE



Special Violin Exercise

While the basses learn a new note, draw the bar lines in the music below. Then write in the counting.



65. LET'S READ "C#" – Review



Eighth Notes

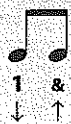

Each Eighth Note = 1/2 Beat
2 Eighth Notes = 1 Beat

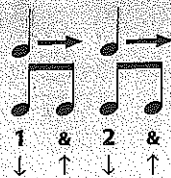

Two or more Eighth Notes have a *beam* across the stems.

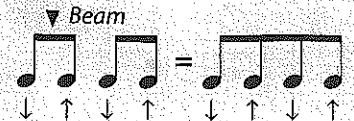

Tap your toe down on the number and up on the "&".

66. RHYTHM RAP

Shadow bow and count before playing.

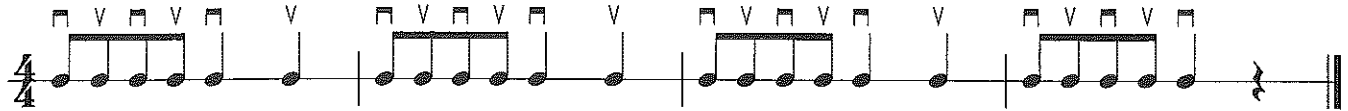

Count: 1 & 2 & 3 & 4 & 1 & 2 & 3 & 4 & 1 & 2 & 3 & 4 & 1 & 2 & 3 & 4 &

67. PEPPERONI PIZZA



68. RHYTHM RAP

Shadow bow and count before playing.

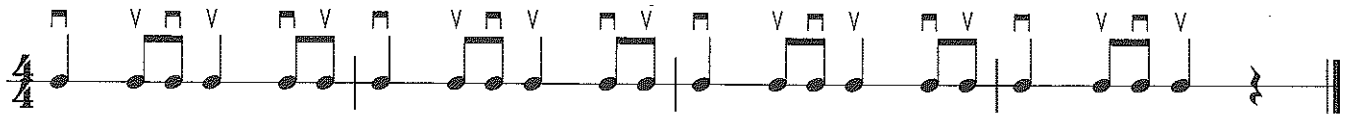

Count: 1 & 2 & 3 & 4 & 1 & 2 & 3 & 4 & 1 & 2 & 3 & 4 & 1 & 2 & 3 & 4 &

69. D MAJOR SCALE UP

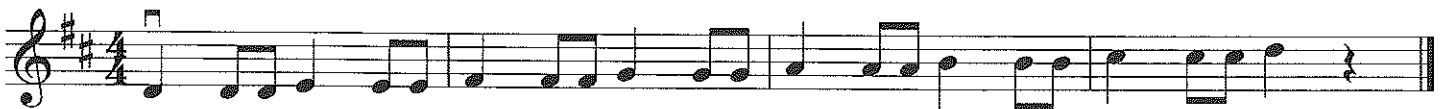

Tempo Markings

Tempo is the speed of music. Tempo markings are usually written above the staff, in Italian.

Allegro - Fast tempo **Moderato** - Medium tempo **Andante** - Slower, walking tempo

70. HOT CROSS BUNS

Moderato

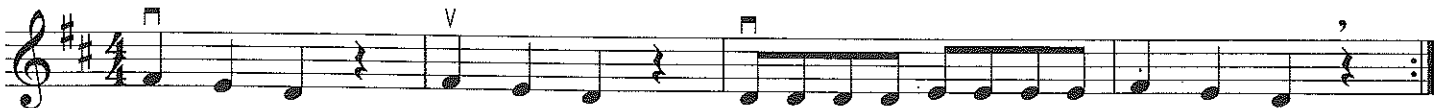

71. AU CLAIRE DE LA LUNE

Andante

French Folk Song



72. RHYTHM RAP

Shadow bow and count before playing.

Count: 1 & 2 & 3 & 4 & 1 & 2 & 3 & 4 & 1 & 2 & 3 & 4 & 1 & 2 & 3 & 4 &

73. BUCKEYE SALUTE

Moderato

2/4 Time Signature

= 2 beats per measure
= Quarter note gets one beat

Conducting

Practice conducting this two-beat pattern.

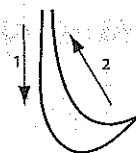

THEORY

74. RHYTHM RAP

Shadow bow and count before playing.

Count: 1 & 2 & 1 & 2 & 1 & 2 & 1 & 2 & 1 & 2 & 1 & 2 & 1 & 2 & 1 & 2 &

75. TWO BY TWO

1st & 2nd Endings



Play the 1st ending the 1st time through. Then, repeat the same section of music, skip the 1st ending, and play the 2nd ending.

THEORY

76. ESSENTIAL ELEMENTS QUIZ - FOR PETE'S SAKE

Moderato

1st time 2nd time

THEORY

Half Note

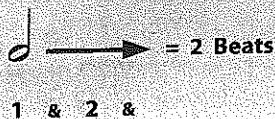

Half Rest

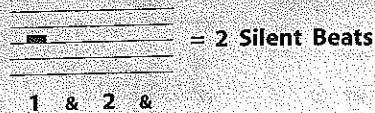

77. RHYTHM RAP

Shadow bow and count before playing.

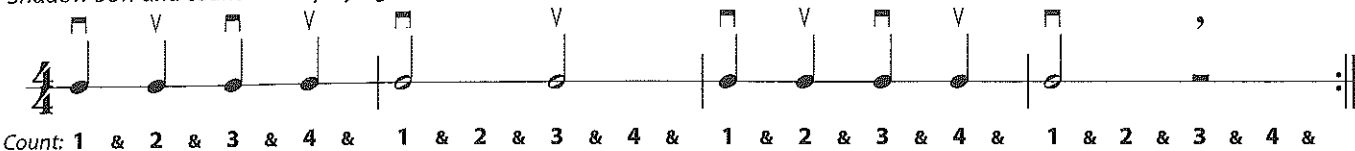

78. AT PIERROT'S DOOR

Moderato

French Folk Song

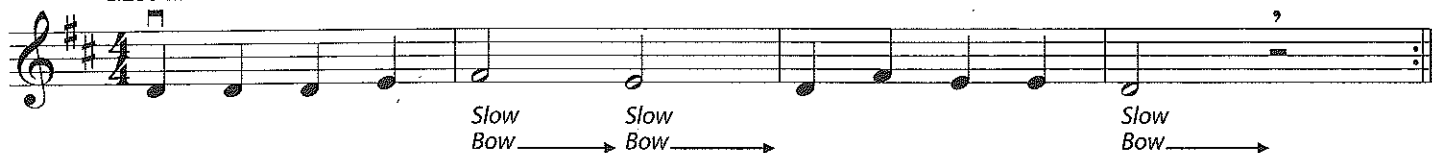

79. THE HALF COUNTS

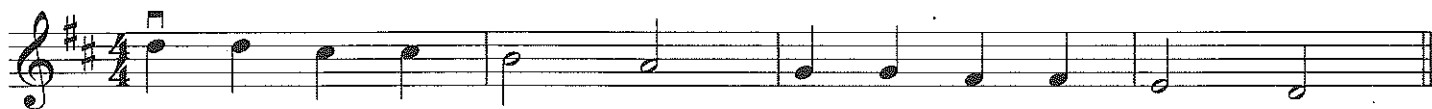

80. GRANDPARENT'S DAY

Andante

American Folk Song

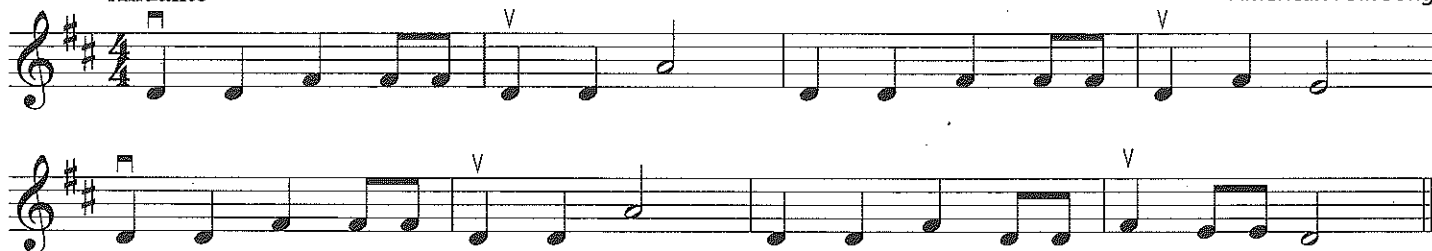

THEORY

Repeat Signs

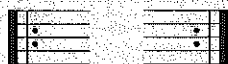

Repeat the section of music enclosed by the **repeat signs**.
(If 1st and 2nd endings are used, they are played as usual—
but go back only to the first repeat sign, not to the beginning.)

81. MICHAEL ROW THE BOAT ASHORE

Moderato

American Folk Song

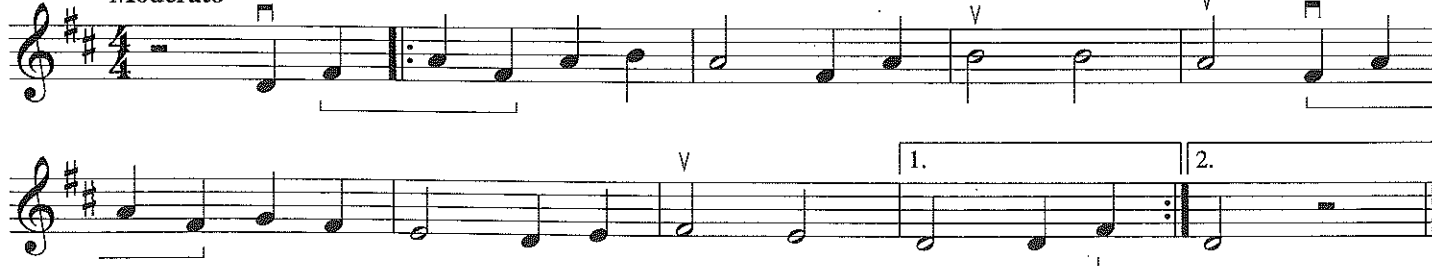

82. TEXAS TWO-STRING

Holding your violin in shoulder position, pizz. this exercise with your left hand 4th finger.
4+ = 4th finger pizz.
(etc.)



4TH FINGER

Your **4th finger** is often used to match the pitch of the next highest open string, creating a smoother tone and fewer changes between strings for bowing.

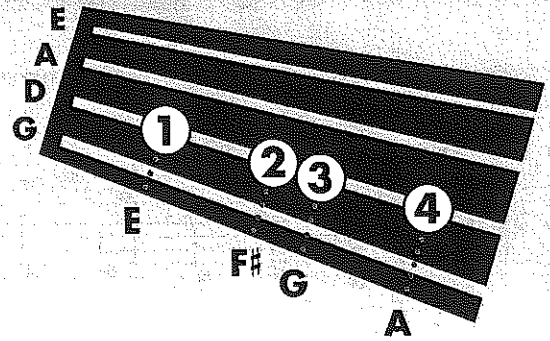
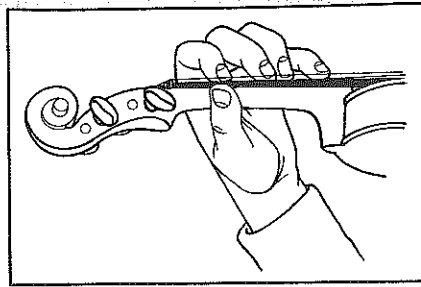

83. FOUR BY FOUR

84. 4TH FINGER MARATHON

85. HIGH FLYING

German composer **Ludwig van Beethoven** (1770–1827) was one of the world's greatest composers. He was completely deaf by 1802. Although he could not hear music like we do, he could "hear" it in his mind. The theme of his final *Symphony No. 9* is called "Ode To Joy," and was written to the text of a poem by Friedrich von Schiller. "Ode To Joy" was featured in concerts celebrating the reunification of Germany in 1990.

HISTORY

86. ESSENTIAL ELEMENTS QUIZ - ODE TO JOY

Ludwig van Beethoven

Moderato

PERFORMANCE SPOTLIGHT

★ Good performers are on time with their instruments and music ready, dressed appropriately, and know their music well.

87. SCALE WARM-UP

88. FRÈRE JACQUES - Round *(When group A reaches ②, group B begins at ①)*

French Folk Song

Moderato

THEORY

Chord, Harmony

Two or more pitches sounding at the same time form a **chord** or **harmony**. Throughout this book, **A** = Melody and **B** = Harmony.

89. BILE 'EM CABBAGE DOWN - Orchestra Arrangement

Allegro

American Fiddle Tune

5 ◀ Measure Number

PERFORMANCE SPOTLIGHT

90. ENGLISH ROUND

Andante

91. LIGHTLY ROW - Orchestra Arrangement

Moderato

French composer **Jacques Offenbach** (1819–1880) was the originator of the **operetta** and played the cello. An **operetta** is a form of entertainment that combines several of the fine arts together: vocal and instrumental music, drama, dance, and visual arts. One of his most famous pieces is the “Can-Can” dance from *Orpheus And The Underworld*. This popular work was written in 1858, just three years before the start of the American Civil War (1861–1865).

HISTORY

92. CAN-CAN - Orchestra Arrangement

Jacques Offenbach
Arr. John Higgins

Allegro

✓ What were the strong points of your performance?

G STRING NOTES

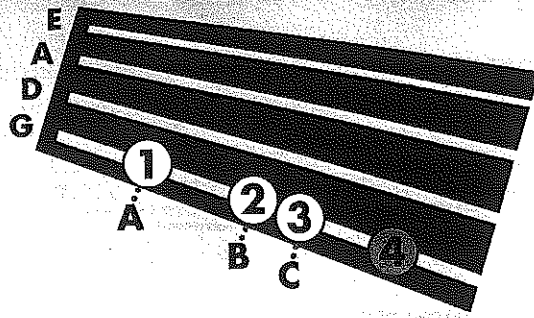

C is played with 3 fingers on the G string.

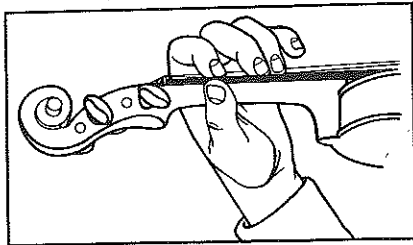

B is played with 2 fingers on the G string.

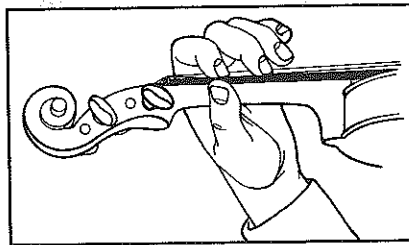

A is played with 1 finger on the G string.

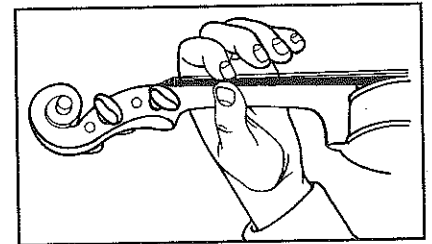

Listening Skills

Play what your teacher plays. Listen carefully.

THEORY

**New Key Signature
G MAJOR**



Play all F's as F# (F-sharp) and all C's as C# (C-natural).

Ledger Lines

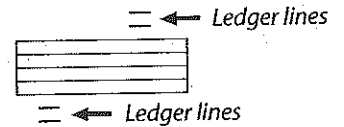

Ledger lines extend the music staff higher or lower.

93. LET'S READ "G"



▲ Play F#'s and C#'s in this key signature.

94. LET'S READ "C" (C-natural)



95. LET'S READ "B"



96. LET'S READ "A"



97. WALKING AROUND Name the notes before you play.

Musical notation for exercise 97, featuring a treble clef, key signature of one sharp (F#), and 4/4 time signature. The melody consists of quarter notes with fingerings 3, 2, 1, 0, and 2 indicated above the staff.

98. G MAJOR SCALE Write the note names before you play.

Musical notation for exercise 98, featuring a treble clef, key signature of one sharp (F#), and 4/4 time signature. The melody consists of quarter notes for the G major scale.

99. FOURTH FINGER D

Musical notation for exercise 99, featuring a treble clef, key signature of one sharp (F#), and 4/4 time signature. The melody consists of quarter notes. A note on the G string is marked with a '4' and a downward arrow, with the text '4th finger on G string = Open D pitch.' written above it.

Time Signature C = Common Time Same as 4/4

Conducting

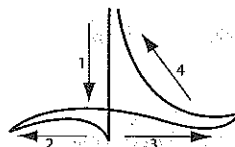

Practice conducting this four-beat pattern.

THEORY

100. LOW DOWN

Musical notation for exercise 100, featuring a treble clef, key signature of one sharp (F#), and common time signature (C). The melody consists of quarter notes with fingerings 4 and 4 indicated above the staff.

101. BAA BAA BLACK SHEEP

Moderato

Musical notation for exercise 101, featuring a treble clef, key signature of one sharp (F#), and common time signature (C). The melody consists of quarter notes with fingerings 4, 0, and 4 indicated above the staff.

102. ESSENTIAL ELEMENTS QUIZ - THIS OLD MAN

Moderato

American Folk Song

Musical notation for exercise 102, featuring a treble clef, key signature of one sharp (F#), and 4/4 time signature. The melody consists of quarter notes with fingerings 4, 4, 0, 0, 4, and 4 indicated above the staff.

Time Signature $\frac{3}{4}$ = 3 beats per measure
 (Meter) $\frac{4}{4}$ = J or z gets one beat

Conducting

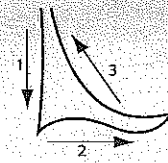

Practice conducting this three-beat pattern.

Dotted Half Note J. \longrightarrow = 3 Beats of Sound
 1 & 2 & 3 &
 ↓ ↑ ↓ ↑ ↓ ↑

Dot
 A dot adds half the value of the note.

$\text{J.} = \text{J.}$
 2 beats + 1 beat = 3 beats

103. RHYTHM RAP

Shadow bow and count before playing.

104. COUNTING THREES

105. D MAJOR SCALE IN THREES

106. FRENCH FOLK SONG

Moderato

French Folk Song

107. ESSENTIAL ELEMENTS QUIZ - SAILOR'S SONG

Allegro

English Sea Song

△ Write in the correct time signature before you begin.

Tie



A **tie** is a curved line that connects notes of the **same** pitch. Play a single note for the combined counts of the tied notes.

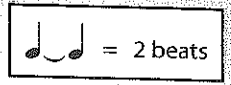

THEORY

108. FIT TO BE TIED

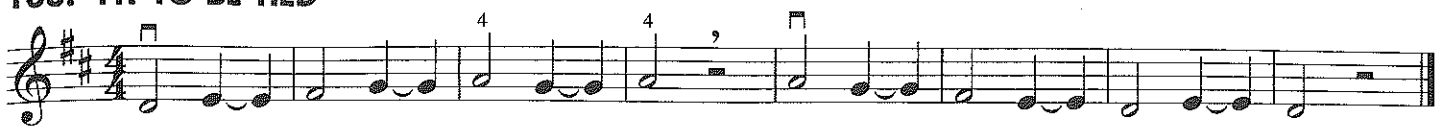

Slur



A **slur** is a curved line that connects two or more **different** pitches. Play slurred notes together in the same bow stroke.

THEORY

109. STOP AND GO

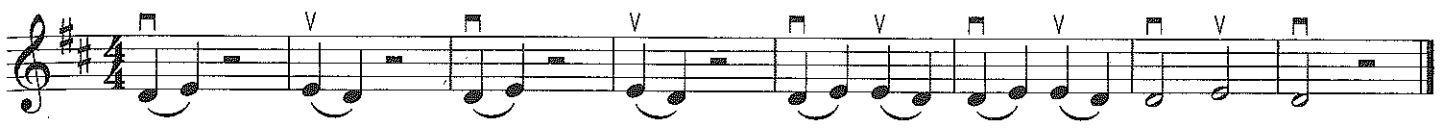

110. SLURRING ALONG

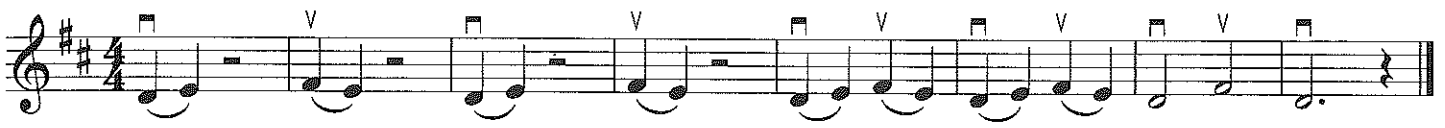

111. SMOOTH SAILING



112. D MAJOR SLURS

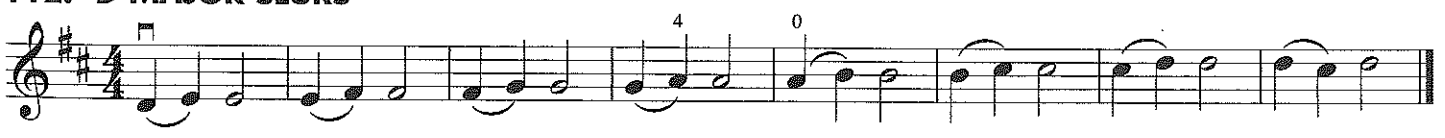

113. CROSSING STRINGS

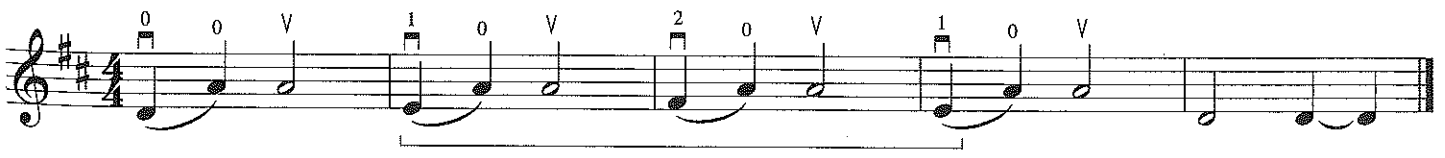

114. GLIDING BOWS

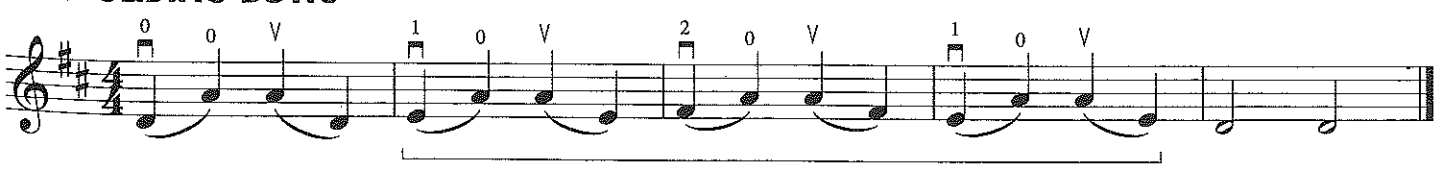

115. UPSIDE DOWN

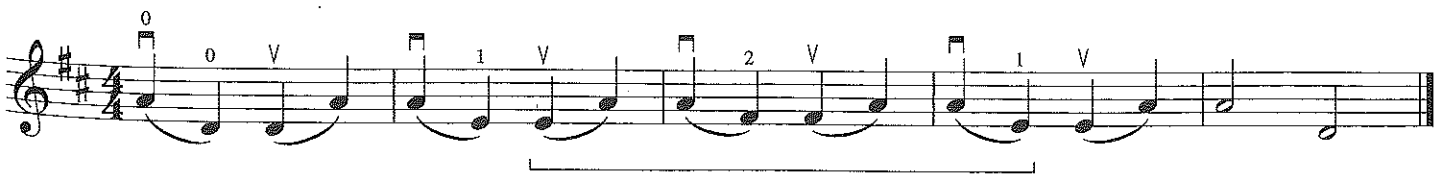

THEORY

Upbeat

A note (or notes) that appears before the first full measure is called an **upbeat** (or **pickup**). The remaining beats are found in the last measure.

116. SONG FOR MARIA

Andante

Musical notation for 'Song for Maria' in G major, 4/4 time. The piece starts with an upbeat (marked with a triangle and 'Upbeat') consisting of a quarter note G. The main melody begins in the first full measure. The notation includes various note values, rests, and dynamic markings like 'V' (accrescendo) and '4' (four notes beamed together). A question mark is placed above the final measure with the text 'Where is beat 4?'.

HISTORY

Latin American music combines the folk music from South and Central America, the Caribbean Islands, African, Spanish, and Portuguese cultures. Melodies often feature a lively accompaniment by drums, maracas, and claves. Latin American styles have become part of jazz, classical, and rock music.

THEORY

D.C. al Fine

Play until you see the **D.C. al Fine**. Then go back to the beginning and play until you see **Fine** (*fee'- nay*). **D.C.** is the abbreviation for **Da Capo**, the Italian term for "return to the beginning." **Fine** is the Italian word for "the finish."

117. BANANA BOAT SONG

Moderato

Caribbean Folk Song

Musical notation for 'Banana Boat Song' in G major, 2/4 time. The piece is marked 'Moderato'. It features a simple melody with a 'Fine' symbol at the end of the first line. A second line of notation starts with a 'D.C. al Fine' instruction, indicating a repeat of the first line. The notation includes note values, rests, and dynamic markings like 'V' and '4'.

118. FIROLIRALERA - Orchestra Arrangement

Allegro

Mexican Folk Song
Arr. John Higgins

Musical notation for 'Firoliralera - Orchestra Arrangement' in G major, 3/4 time. The piece is marked 'Allegro'. It is arranged for two parts, A and B. Part A starts with an upbeat (marked with a triangle and 'Upbeats') consisting of a quarter note G. The notation includes various note values, rests, dynamic markings like 'V' (accrescendo) and '4' (four notes beamed together), and a 'Tie' symbol at the end. The arrangement is complex, with multiple lines of notation for each part.

SKILL BUILDERS - G Major

119.



120.



121.



122.



123.



124.

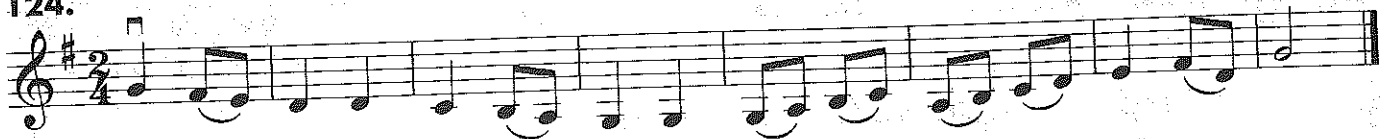

Far Eastern music comes from Malaysia, Indonesia, China and other areas. Historians believe the first orchestras, known as **gamelans**, existed in this region as early as the 1st century B.C. Today's gamelans include rebabs (spiked fiddles), gongs, xylophones, and a wide variety of percussion instruments.

HISTORY

125. JINGLI NONA

Far Eastern Folk Song

Allegro

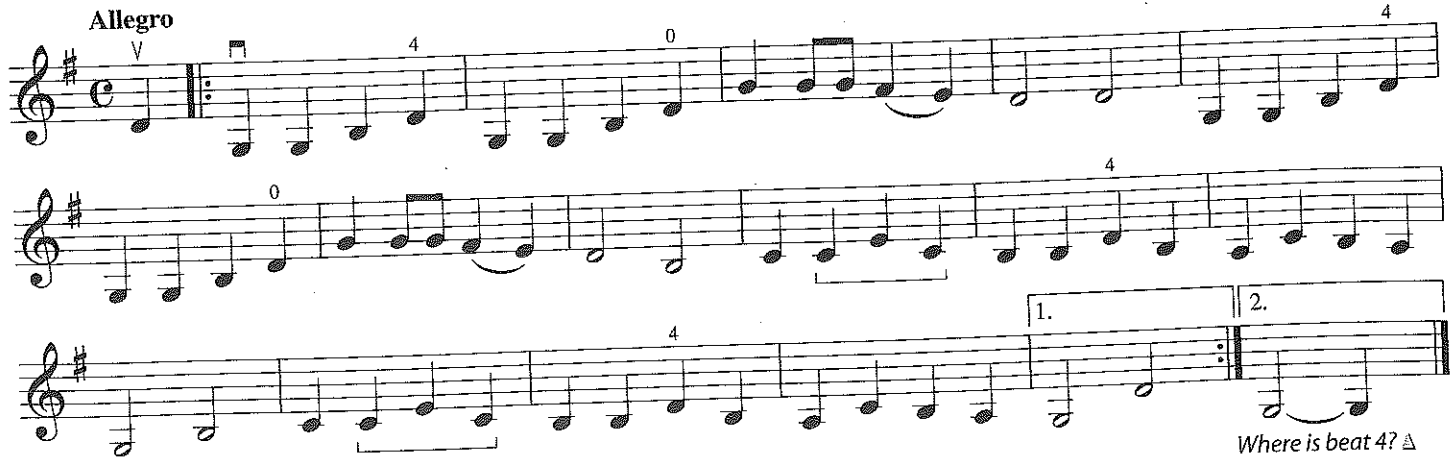

Where is beat 4? Δ

NEW FINGER PATTERN

Low 2nd Finger

Step 1

Shape your left hand as shown. Be certain your palm faces you. Notice your 2nd finger lightly touches your 1st finger.

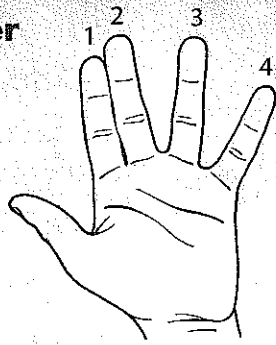

Step 2

Bring your hand to the fingerboard. Your 1st and 2nd fingers touch. There is a space between your 2nd and 3rd fingers, and between your 3rd and 4th fingers.

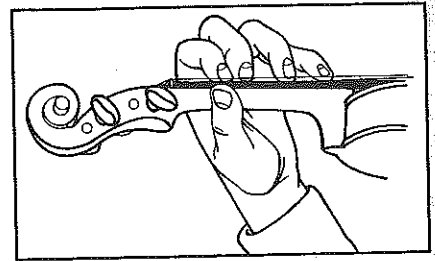

F

is played with low 2nd finger on the D string.

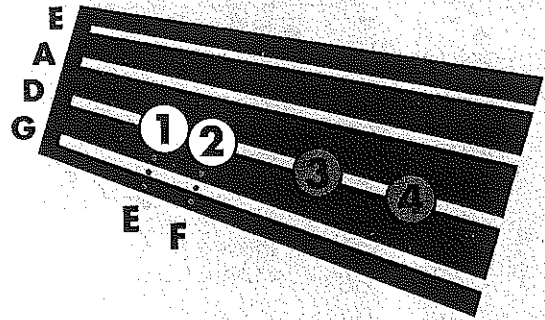
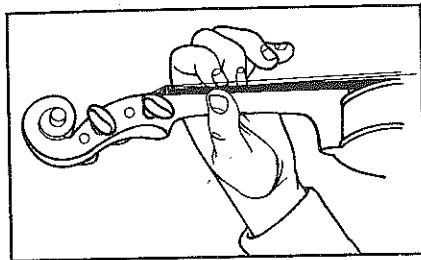

Listening Skills

Play what your teacher plays. Listen carefully.

THEORY

Natural



A natural sign cancels a flat (b) or sharp (#) and remains in effect for the entire measure.

126. LET'S READ "F" (F-natural)

↓ Low 2nd finger



THEORY

Half Step

A half step is the smallest distance between two notes.

Whole Step

A whole step is two half steps combined.

127. HALF-STEPPIN' AND WHOLE STEPPIN'

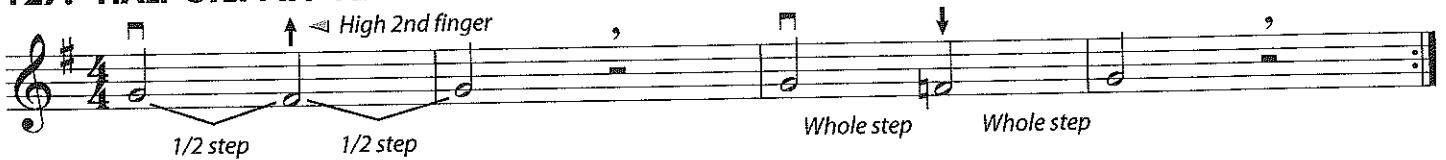

128. SPY GUY

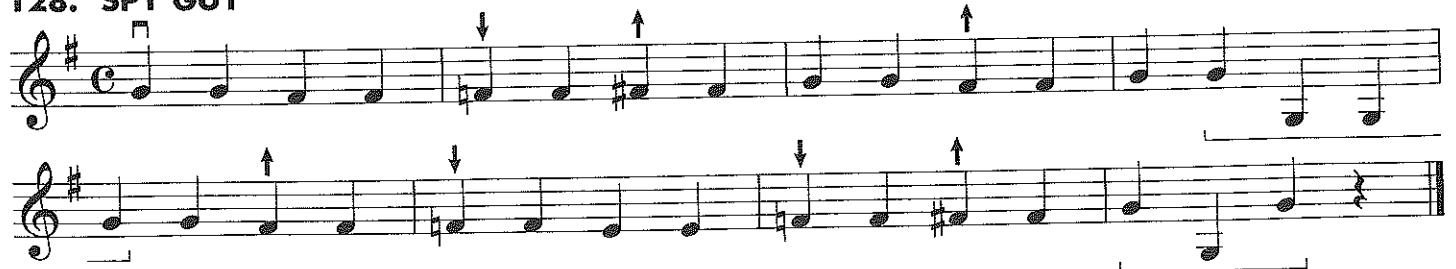

129. MINOR DETAILS



NEW FINGER PATTERN

Low 2nd Finger On The A String

Shape your left hand on the A string as shown.

C is played with low 2nd finger on the A string.

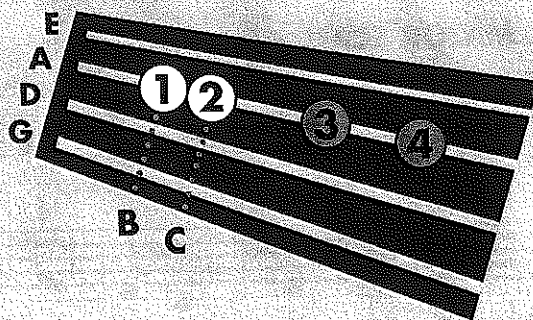
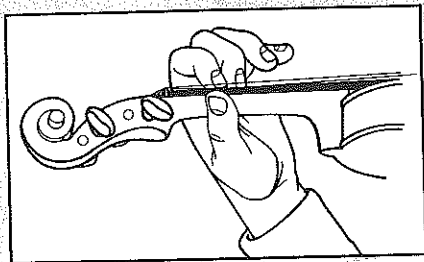

Listening Skills Play what your teacher plays. Listen carefully.

130. LET'S READ "C" (C-natural)

C

131. HALF STEP AND WHOLE STEP REVIEW

Chromatics

Chromatic notes are altered with sharps, flats, and naturals. A chromatic pattern is two or more notes in a sequence of half steps.

THEORY

132. CHROMATIC MOVES

133. THE STETSON SPECIAL

134. BLUEBIRD'S SONG

Texas Folk Song

Allegro

Key Signature C MAJOR



All notes are naturals.

135. C MAJOR SCALE - Round

Duet

A composition with two different parts, played together.

136. SPLIT DECISION - Duet

137. OAK HOLLOW

Moderato

138. A-TISKET, A-TASKET

Allegro

HISTORY

In the second half of the 1800s many composers tried to express the spirit of their own country by writing music with a distinct national flavor. Listen to the music of Russian composers such as Borodin, Tchaikovsky, and Rimsky-Korsakov. They often used folk songs and dance rhythms to convey their nationalism. Describe the sounds you hear.

139. ESSENTIAL ELEMENTS QUIZ - RUSSIAN FOLK TUNE

Andante

Russian Folk Song



Alert: This page mixes finger patterns. Watch for low second finger (C4) and high second finger (F#).

140. BINGO

18th Century English Game Song

Allegro

HISTORY

English composer **Thomas Tallis** (1505–1585) served as royal court composer during the reigns of Henry VIII, Edward VI, Mary, and Elizabeth I. Composers and artists during this era wanted to recreate the artistic and scientific glories of ancient Greece and Rome. The great artist Michelangelo painted the Sistine Chapel during Tallis' lifetime. **Rounds** and **canons** were popular forms of music during the early 16th century. Divide into groups, and play or sing the *Tallis Canon* as a 4-part round.

141. TALLIS CANON - Round

Thomas Tallis

Moderato

THEORY

Theme and Variations

Theme and Variations is a musical form where a theme, or melody, is followed by different versions of the same theme.

142. VARIATIONS ON A FAMILIAR SONG

Moderato

Variation 2 – make up your own variation

143. ESSENTIAL CREATIVITY - THE BIRTHDAY SONG

Moderato

Now play the line again and create your own rhythm.

Special Violin Exercise

Write the note names below. Then, write stories using as many note names as possible. Share your work with orchestra friends.



Note Names: _____

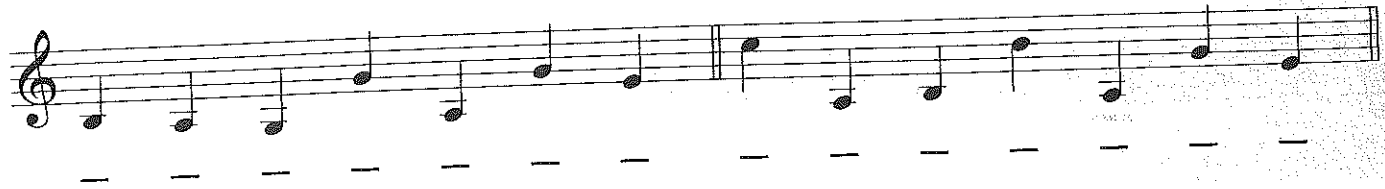

Team Work

Great musicians give encouragement to their fellow performers. Viola and cello players will now learn new challenging notes. The success of your orchestra depends on everyone's talent and patience. Play your best as these sections advance their musical technique.

Listening Skills

Play what your teacher plays. Listen carefully.

144. LET'S READ "C" - Review

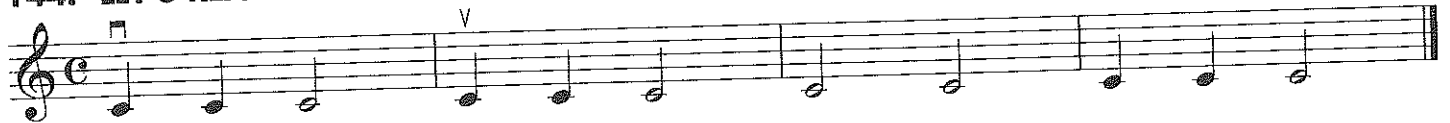

145. LET'S READ "F" - Review



146. LET'S READ "E" - Review

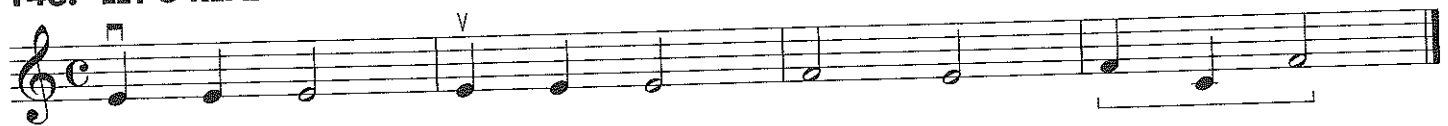

147. LET'S READ "D" - Review

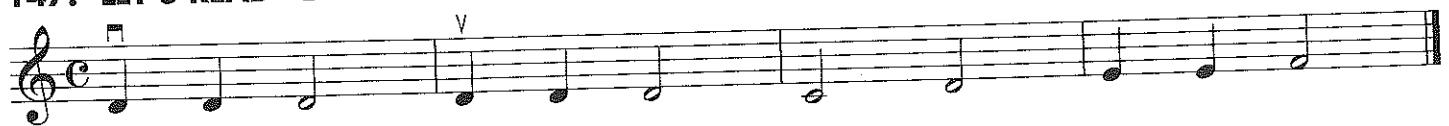

148. SIDE BY SIDE *Name the notes before you play.*

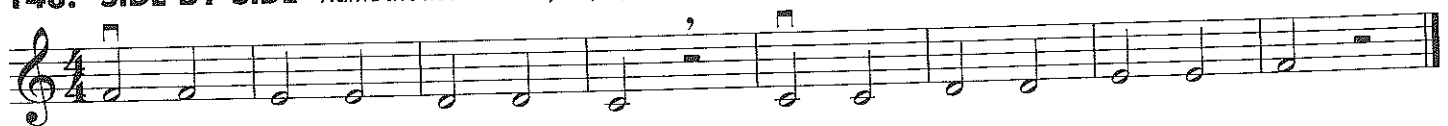

149. C MAJOR SCALE



Whole Note

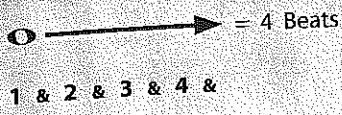

Whole Rest

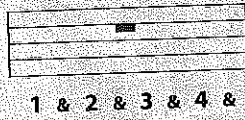

A Whole Measure of Silent Beats

Whole Rest



Half Rest

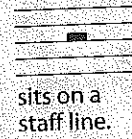

THEORY

150. RHYTHM RAP

Shadow bow and count before playing.

Count: 1 & 2 & 3 & 4 & 1 & 2 & 3 & 4 & 1 & 2 & 3 & 4 & 1 & 2 & 3 & 4 & 1 & 2 & 3 & 4 & 1 & 2 & 3 & 4 & 1 & 2 & 3 & 4 &

151. SLOW BOWS

Slow Bow

152. LONG, LONG AGO

T.H. Baily

Moderato

Arpeggio

An **arpeggio** is a chord whose pitches are played one at a time. Your first arpeggio uses the 1st, 3rd, 5th, and 8th steps from the C major scale.

THEORY

153. C MAJOR SCALE AND ARPEGGIO

Arpeggio

154. LISTEN TO OUR SECTIONS

Violin Viola Cello Bass Vln. Vla. Vcl. Bs. All

155. MONDAY'S MELODY

Traditional Folk Song

Moderato

Fine

D.C. al Fine

E STRING NOTES

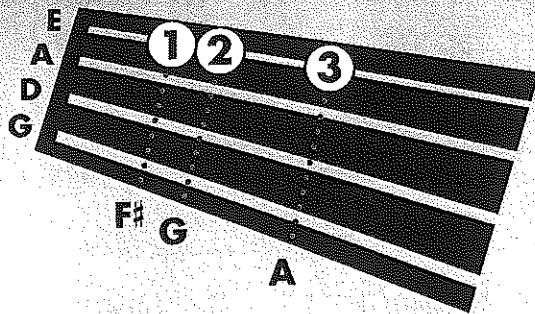

A is played with 3 fingers on the E string.

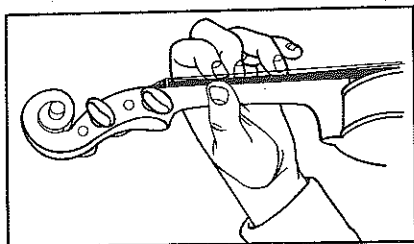

G is played with 2 fingers on the E string.

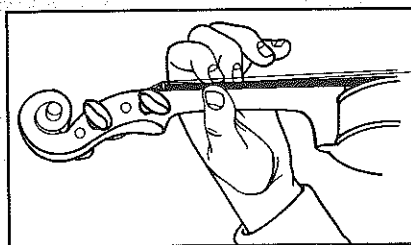

F# is played with 1 finger on the E string.

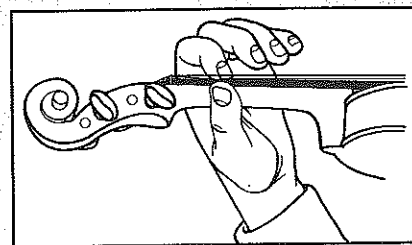

Listening Skills Play what your teacher plays. Listen carefully.

156. LET'S READ "E"



157. LET'S READ "A"



158. LET'S READ "G"

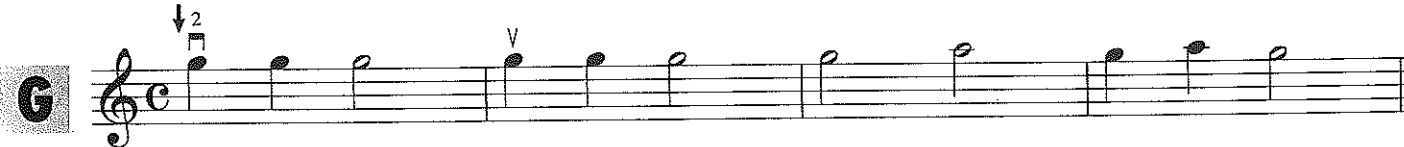

159. LET'S READ "F#" (F-sharp)



160. MOVING ALONG Name the notes before you play.

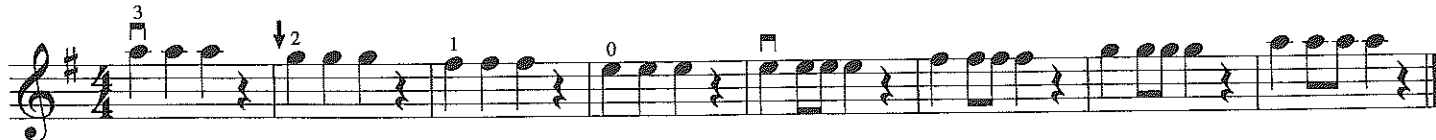

161. G MAJOR SCALE

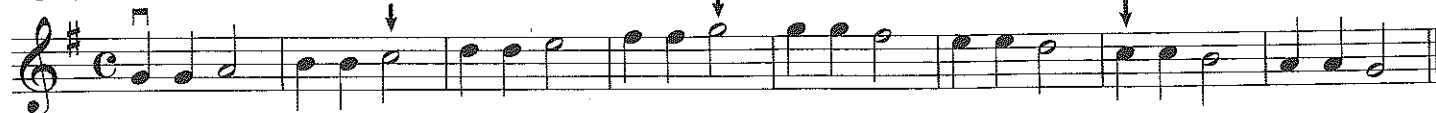

162. SHEPHERD'S HEY
Moderato

English Folk Song

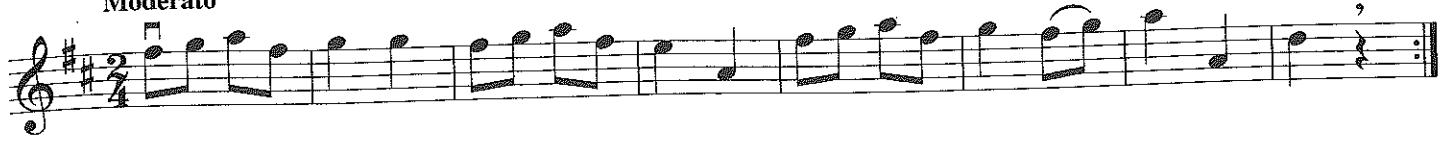

163. BIG ROCK CANDY MOUNTAIN
Allegro

American Folk Song

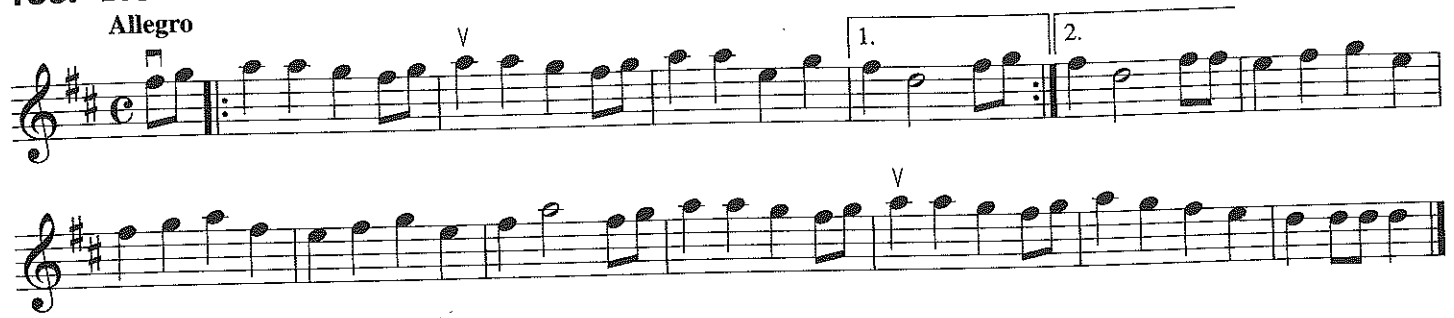

NEW NOTE

B is played with 4 fingers on the E string.

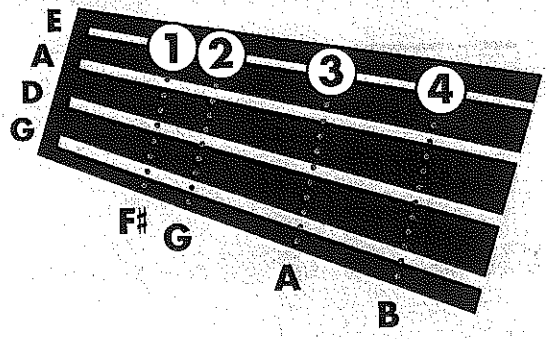
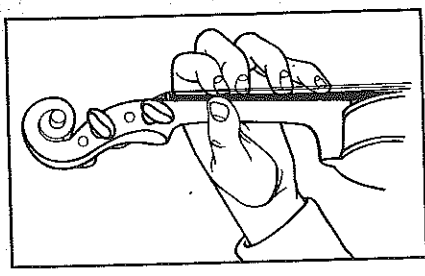

Listening Skills

Play what your teacher plays. Listen carefully.

164. LET'S READ "B"

B



165. ICE SKATING
Moderato



166. ESSENTIAL ELEMENTS QUIZ - ACADEMIC FESTIVAL OVERTURE THEME
Moderato

Johannes Brahms



Staccato

Staccato notes are marked with a dot above or below the note. A staccato note is played with a stopped bow stroke. Listen for a space between staccato notes.

167. PLAY STACCATO
168. ARKANSAS TRAVELER*Allegro*

Southern American Folk Song

**SKILL BUILDERS - G Major**

169.

170.

171.

172.

▼ 4th finger on A string = open E pitch

173.

Hooked Bowing



Hooked bowing is two or more notes played in the same direction with a stop between each note.

174. HOOKED ON D MAJOR

175. WALTZING BOWS

176. POP GOES THE WEASEL

Allegro

American Folk Song

SKILL BUILDERS - C Major

177.

178.

179.

180.

Dynamics

Dynamics tell us what volume to play or sing.

f (forte)*p* (piano)

Play loudly. Add more weight to the bow.

Play softly. Remove weight from the bow.

181. FORTE AND PIANO
182. SURPRISE SYMPHONY THEME

Andante

Franz Josef Haydn

SKILL BUILDERS - Scales and Arpeggios

Add your own dynamics to any of the lines below.

183. D MAJOR
184. G MAJOR
185. G MAJOR
186. C MAJOR
187. C MAJOR (Lower Octave - viola and cello)

PERFORMANCE SPOTLIGHT

188. CRIPPLE CREEK - Orchestra Arrangement (A = Melody and B = Harmony)

American Folk Song
Arr. Michael Allen

Allegro

The score for 'Cripple Creek' is in 4/4 time with a key signature of two sharps (F# and C#). It consists of two systems of staves. The first system shows measures 1-4, and the second system shows measures 5-8. Part A (Melody) and Part B (Harmony) are both marked with a forte (*f*) dynamic. The melody features a mix of quarter and eighth notes, with some measures containing a 'V' symbol above the staff. The harmony consists of a steady eighth-note accompaniment.

Africa is a large continent made up of many nations, and African folk music is as diverse as its many cultures. This folk song is from Kenya. The words describe warriors as they prepare for battle. Listen to examples of African folk music and describe the sound.

HISTORY

189. TEKELE LOMERIA - Orchestra Arrangement

Kenyan Warrior Song
Arr. John Higgins

Moderato

The score for 'Tekele Lomeria' is in common time (C) with a key signature of one sharp (F#). It consists of two systems of staves. The first system shows measures 1-3, and the second system shows measures 4. Part A (Melody) and Part B (Harmony) are both marked with a forte (*f*) dynamic. The melody features a mix of quarter and eighth notes, with some measures containing a 'V' symbol above the staff. The harmony consists of a steady eighth-note accompaniment. The second system includes dynamic markings of piano (*p*) and forte (*f*) for both parts, and a '4' symbol above the staff in measure 4.

PERFORMANCE SPOTLIGHT

HISTORY

Italian composer **Gioachino Rossini** (1792–1868) wrote some of the world's favorite operas. "William Tell" was Rossini's last opera, and its popular theme is still heard on television.

190. WILLIAM TELL OVERTURE - Orchestra Arrangement

Gioachino Rossini
Arr. John Higgins

Allegro

A

B

p

f

p

f

Fine 9

p

p

D.C. al Fine

f

f

191. ROCKIN' STRINGS - Orchestra Arrangement

John Higgins

Moderato

A

B

f

f

1.

2.

PERFORMANCE SPOTLIGHT

Shaker Folk Song
Arr. John Higgins

192. SIMPLE GIFTS - Orchestra Arrangement

Andante

The musical score is written for two staves, A and B, in a 4/4 time signature with a key signature of two sharps (F# and C#). The tempo is marked 'Andante'. The score consists of five systems of two staves each. The first system (measures 1-4) begins with a forte (*f*) dynamic. The second system (measures 5-8) continues with the forte dynamic and includes fingering numbers (0, 4) and a 'V' (vibrato) marking. The third system (measures 9-12) starts with a piano (*p*) dynamic, indicated by a box containing the number '10' and a '4' above the staff. The fourth system (measures 13-16) returns to a forte (*f*) dynamic. The fifth system (measures 17-20) concludes with a piano (*p*) dynamic. The score includes various musical notations such as slurs, ties, and fingering numbers (0, 4) for both staves.

PERFORMANCE SPOTLIGHT

Solo with Piano Accompaniment

A solo is a composition written for one player, often with piano accompaniment. This solo was written by **Johann Sebastian Bach** (1685–1750). You and a piano accompanist can perform for the orchestra, your school, your family, and at other occasions. When you have learned the piece well, try memorizing it. Performing for an audience is an exciting part of being involved in music.

193. MINUET NO. 1 - Solo

Johann Sebastian Bach
Arr. John Higgins

Moderato

f

p

f

Piano Accompaniment

Moderato

mf

p

f

Improvisation

Improvisation is the art of freely creating your own music as you play.

194. RHYTHM JAM Using the following notes, improvise your own rhythms.



195. INSTANT MELODY Using the following notes, improvise your own melody (Line A), to go with the accompaniment (Line B).



VIOLIN FINGERING CHART

String	0	1	2	3	4	
E STRING						
A STRING						
D STRING						
G STRING						

REFERENCE INDEX

Definitions (pg.)

Allegro 20
 Alto Clef 5 (*viola*)
 Andante 20
 Arco 16
 Arpeggio 37
 Bar Lines 4
 Bass Clef 5 (*cello & bass*)
 Beat 4
 Bow Lift 17
 Chord 24
 Chromatics 33
 Common Time 27
 Counting 5
 D.C. al Fine 30
 Dotted Half Note 28
 Double Bar 5
 Down Bow 13
 Duet 34
 Dynamics 42
 Eighth Notes 20
 1st & 2nd Endings 21
 Forte (*f*) 42
 Half Note 22
 Half Rest 22
 Half Step 32
 Harmony 24
 Hooked Bowing 41
 Improvisation 47
 Key Signature 15
 Ledger Lines 26
 Measures 4
 Measure Number 24
 Moderato 20
 Music Staff 4
 Natural 32
 Piano (*p*) 42
 Pickup 30
 Pizzicato (*pizz.*) 4
 Quarter Note 4
 Quarter Rest 4

Repeat Sign 5
 Repeat Signs (enclosed) 22
 Round 24
 Scale 11
 Shadow Bowing 13
 Sharp 6
 Slur 29
 Solo 46
 Staccato 40
 Tempo Markings 20
 Theme And Variations 35
 Tie 29
 Time Signature 5
 Treble Clef 5 (*violin*)
 Up Bow 13
 Upbeat 30
 Whole Note 37
 Whole Rest 37
 Whole Step 32

Composers

JOHANN SEBASTIAN BACH

• Minuet No. 1 46

LUDWIG VAN BEETHOVEN

• Ode To Joy (from Sym. No. 9) 23

JOHANNES BRAHMS

• Academic Festival Overture Theme 39

FRANZ JOSEF HAYDN

• Surprise Symphony Theme 42

WOLFGANG AMADEUS MOZART

• A Mozart Melody 15

JACQUES OFFENBACH

• Can-Can From "Orpheus And The Underworld" 25

GIOACCHINO ROSSINI

• William Tell Overture 44

THOMAS TALLIS

• Tallis Canon 35

World Music

AFRICAN

• Tekele Lomeria 43

AMERICAN

• Arkansas Traveler 40
 • Big Rock Candy Mountain 39
 • Bile 'Em Cabbage Down 24
 • Bluebird's Song 33
 • Cripple Creek 43
 • Grandparents Day 22
 • Michael Row The Boat Ashore 22
 • Old MacDonald Had A Farm 14
 • Monday's Melody 37
 • Pop Goes The Weasel 41
 • Skip To My Lou 35
 • Simple Gifts 45
 • This Old Man 27

CARIBBEAN

• Banana Boat Song 30

ENGLISH

• Bingo 35
 • English Round 25
 • Sailor's Song 28
 • Shepherd's Hey 39

FAR EASTERN

• Jingli Nona 31

FRENCH

• At Pierrot's Door 22
 • Au Claire De La Lune 20
 • French Folk Song 28
 • Frère Jacques 24

MEXICAN

• Fioliralera 30

RUSSIAN

• Russian Folk Song 34

SLAVIC

• Morning Dance 8

WELSH

• Good King Wenceslas 9

TRADITIONAL HOLIDAY MUSIC

• Dreidel 13
 • Jingle Bells 14